



SUZUKI
MARINE

Parts Book
DT 2 80-82

PTBK100B

PREFACE

When it becomes necessary to replace parts on SUZUKI OUTBOARD MOTORS, always use SUZUKI GENUINE PARTS which have passed a strict inspection which guarantees quality and performance.

This parts catalogue covers the list of all service parts for SUZUKI DT2G, DT2J, DT2VZ.

A. INSTRUCTIONS FOR QUOTING THE CATALOGUE

1. DIMENSIONS

Dimensions of the parts in this catalogue are indicated in unit millimeters.

2. ABBREVIATIONS

Abbreviations used in this catalogue are as follows:

AR	: As required	NT	: Number of teeth
ASSY	: Assembly	OPT	: Optional
E.No.	: Engine Number	OS	: Over Size
F.No.	: Frame Number	STD	: Standard
d	: Diameter of material	T	: Thickness
ID	: Inside diameter	US	: Under size
OD	: Outside diameter	W	: Width
L	: Length	LHD	: Left handle drive
LH	: Left hand side	RHD	: Right handle drive
RH	: Right hand side	S,L,UL,LL	: Transom type
~123456	: Up to E.No.0201-123456		
123456~	: From E.No.0201-123456		

12 x 34 x 5.6 Figures in the description column show the dimensions of parts.
 | | |
 ID OD T(or W,L)

The number of letter shown below Q'ty indicate the MODEL NAME as shown below.

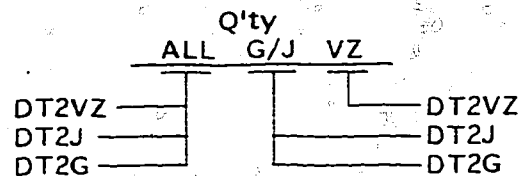

3. INNER PARTS OF ASSEMBLY

Parts number that have a period (.) mark in front of the part description on a text page are separately serviced parts of the assembly.

4. MODIFICATION NOTICE

A parts bulletin will be sent to you on all occasions when changes in parts occur, including interchangeable modifications between new parts and old ones.

5. NOTE

- 5-1. There are some different parts from those of production models among spare parts for the administrative reasons and common use of them with other models.
- 5-2. In respect of rubber hoses and vinyl tubes, please be sure to use them by cutting off according to the length mentioned on parts catalogue or what is actually required on the vehicle.
- 5-3. Note that the drawings on the illustration page are for ready reference of spare parts number, not to be used as an assembly manual.
When assembling, use "SUZUKI SERVICE MANUAL".

6. SPECIFICATION CODE

This catalogue contains the parts for the model designed for the following spec. ;
 spec. code: G (E1, E3), J (E1, E3, E13), VZ (E1, E13)

7. SERIAL ENGINE NUMBER



FIG.1

B - 2

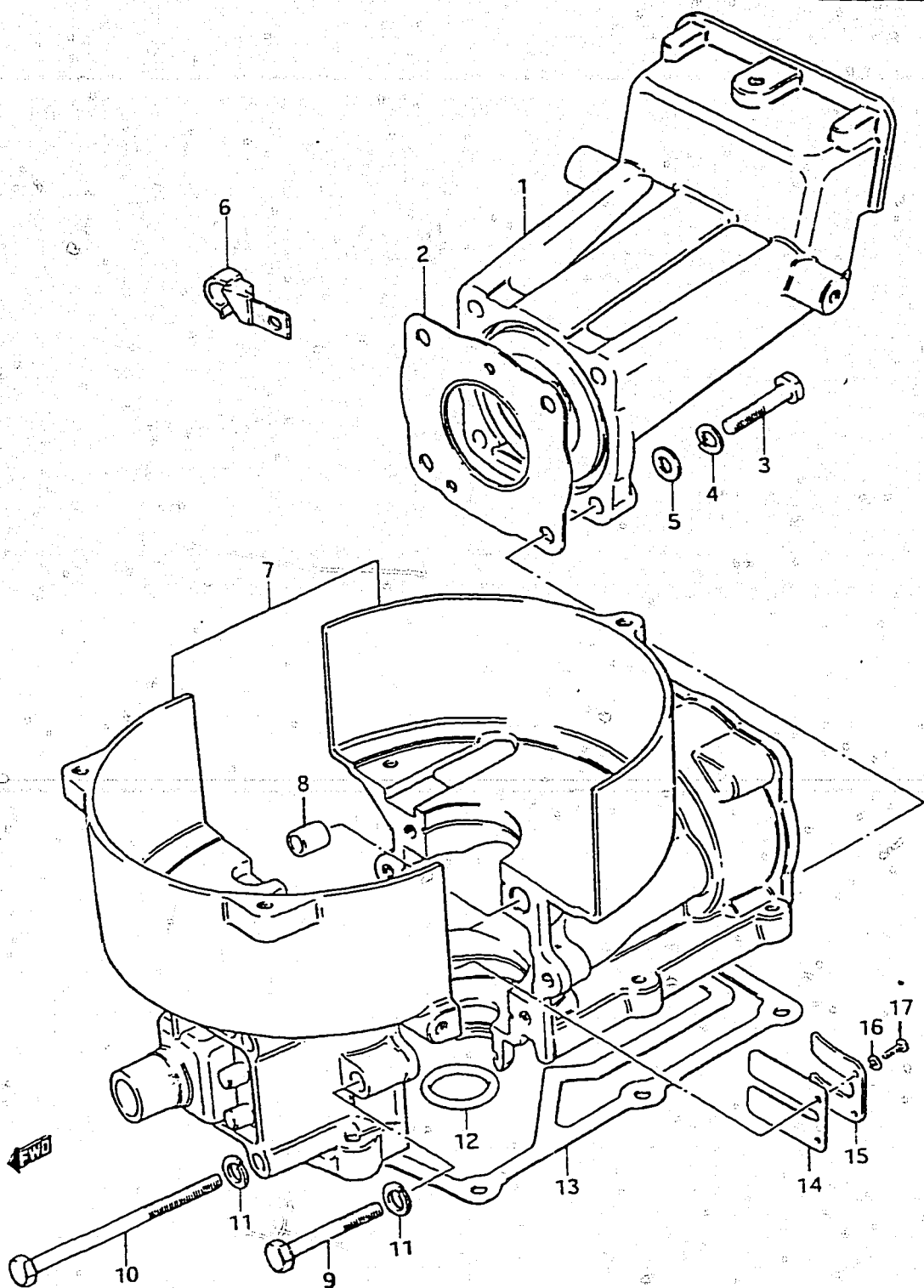

FIG.1 CYLINDER

Ref. No.	Part No.	Description	Q'ty	ALL	Remarks
1-1	11111-98401-01J	CYLINDER HEAD	1		model G
1-2	11111-98402-01J	CYLINDER HEAD	1		model J, VZ from 11111-98401-01J
2-1	11141-98400	GASKET, cylinder head	1		model G, J
2-2	11141-98401	GASKET, cylinder head	1		model VZ from 11141-98400
3-1	01107-06308	BOLT	4		model G, J
3-2	01907-06308	BOLT	4		model VZ to 01107-06308
4	08321-21068	LOCK WASHER	4		
5	08322-21068	WASHER	4		
6	09403-10309	CLAMP	1		
7-1	11300-98842-01J	CYLINDER/CRANKCASE ASSY	1		to 11300-98400-01J
7-2	11300-98400-01J	CYLINDER/CRANKCASE ASSY	1		model G
7-3	11301-98400-01J	CYLINDER/CRANKCASE ASSY	1		from 11300-98400-01J
7-4	11301-98401-01J	CYLINDER/CRANKCASE ASSY (to 11301-98402-01J)	1		model J from 11301-98400-01J
7-5	11301-98402-01J	CYLINDER/CRANKCASE ASSY	1		
7-6	11301-98403-01J	CYLINDER/CRANKCASE ASSY	1		model VZ
8	04211-09109	-DOWEL PIN	2		
9-1	01107-06358	-BOLT	2		model G, J
9-2	01907-06358	-BOLT	2		model VZ to 01107-06358
10	09100-06062	-BOLT (6x70)	4		
11	08321-21068	-LOCK WASHER	6		
12	09280-20002	O RING, cylinder	1		ID:19.4,d:3.1
13	52113-98400	GASKET, drive shaft housing	1		
14	13153-19012	VALVE, reed	1		
15	13152-19010	STOPPER, reed valve	1		
16	08321-21038	LOCK WASHER	2		
17	02112-03088	SCREW	2		

FIG.2

B - 3

FIG.2 PISTON / CRANKSHAFT

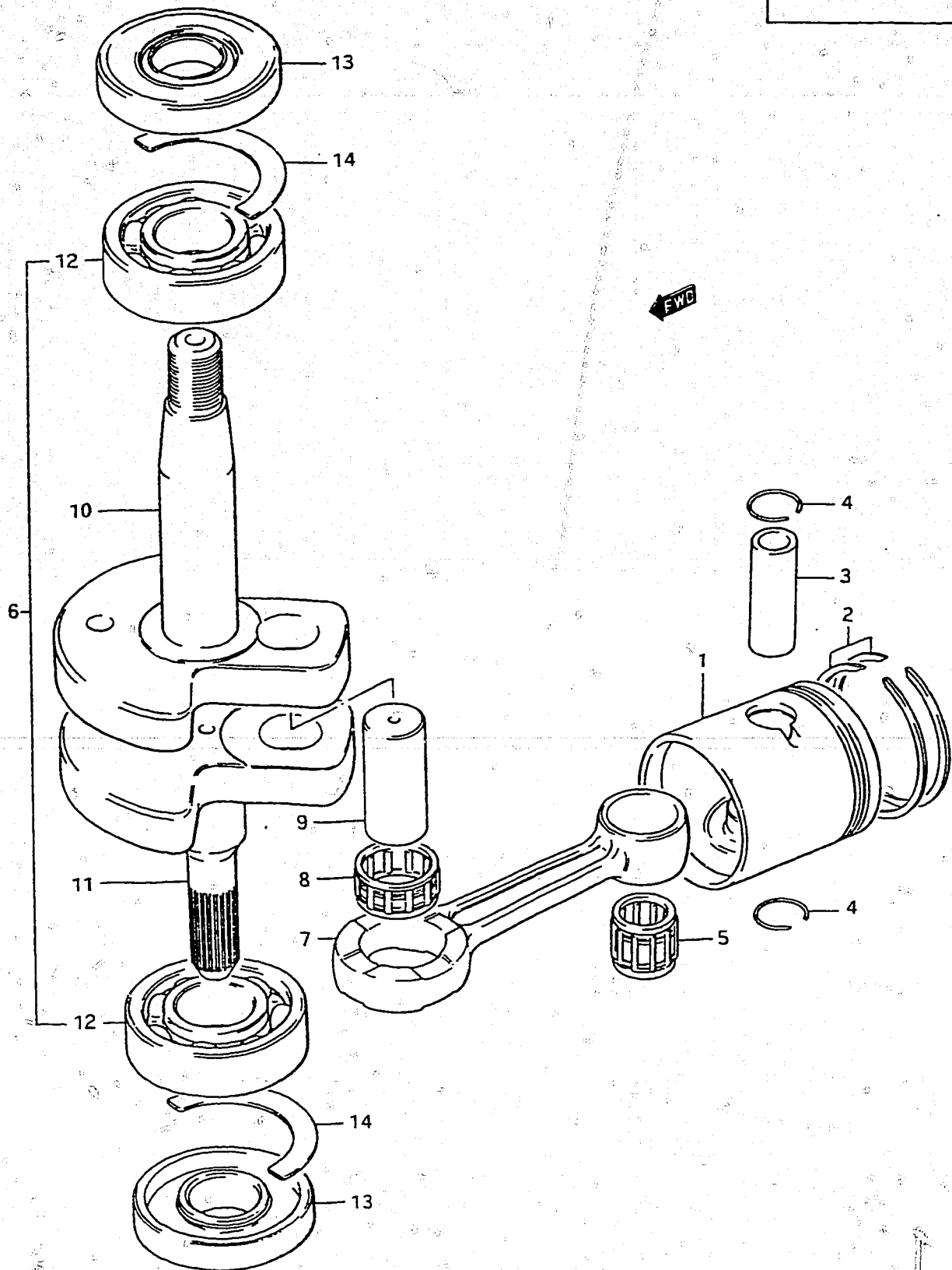

Ref. No.	Part No.	Description	Q'ty	ALL	Remarks
1-1	12110-98402	PISTON	1		
1-2	12110-98402-025	PISTON (OS:0.25)	1	OPT	
1-3	12110-98402-050	PISTON (OS:0.5)	1	OPT	
2-1	12140-98400	RING SET, piston	1		
2-2	12140-98401-025	RING SET, piston (OS:0.25)	1	OPT	
2-3	12140-98401-050	RING SET, piston (OS:0.5)	1	OPT	
3	12151-02000	PIN, piston	1		
4	09381-12001	CIRCLIP, piston pin	2		
5-1	09263-12003	BEARING, piston pin	1		12x16x15.8,model G,J to 09263-12015
5-2	09263-12015	BEARING, piston pin	1		12x16x15.8,model VZ
6-1	12200-98830	CRANKSHAFT ASSY	1		model G
6-2	12200-98401	CRANKSHAFT ASSY	1		model J,VZ from 12200-98830
7	12161-98400	·ROD, connecting	1		
8	09263-15014	·BEARING, crank pin	1		15x21x9.8
9	12211-04000	·PIN, crank	1		
10	12221-98400	·CRANKSHAFT, upper	1		
11	12231-98400	·CRANKSHAFT, lower	1		
12	09262-17008	·BEARING	2		
13	09283-17002	OIL SEAL, crankshaft	2		17x40x7
14	09390-40003	RING, thrust	2		

FIG.3

B - 4

FIG.3 CARBURETOR

Ref. No.	Part No.	Description	Q'ty		Remarks
			ALL		
1	13200-98411	CARBURETOR ASSY	1		stamp:98411
2	13433-98410	•SCREW	1		
3	13426-98410	•LOCK WASHER	1		
4	13615-98412	•WASHER	1		
5	13432-33110	•RING, friction	1		
6	13564-98411	•LEVER ASSY, throttle	1		
7	04111-12108	•COTTER PIN	1		
8	13557-98410	•PLATE	2		model G,J
9	13557-98410	•PLATE	1		model VZ
10	13557-98420	•PLATE	1		
11-1	13567-98411	•NUT	1		to 13567-98412, model G
11-2	13567-98412	•NUT	1		
12	13589-98411	•WASHER	1		
13	13265-98411	•TOP, carburetor	1		
14-1	13573-98410	•SPRING	1		to 13573-98411, model G
14-2	13573-98411	•SPRING	1		model J, VZ
15	13552-98411	•PIPE	1		
16	13533-98410	•E RING	1		
17	13545-98410	•SEAT, spring	1		
18	13552-98410	•ROD, throttle	1		
19	13563-98410	•PIN, seat	1		
20	13394-12110	•CLIP	1		
21	13383-98410	•NEEDLE, jet	1		
22	13551-98411	•VALVE, throttle (CA:1.5)	1		
23	13267-01010	•SCREW, stop	1		
24	13268-01010	•SPRING	1		
25	13295-98410	•O RING	1		
26	13376-98400	•FILTER	1		
27	13392-01010	•GASKET, valve seat	1		
28	13370-23010	•VALVE ASSY, needle	1		
29	09494-00179	•NOZZLE, needle	1		
30	13252-98410	•FLOAT	1		
31	13253-98410	•ARM, float	1		

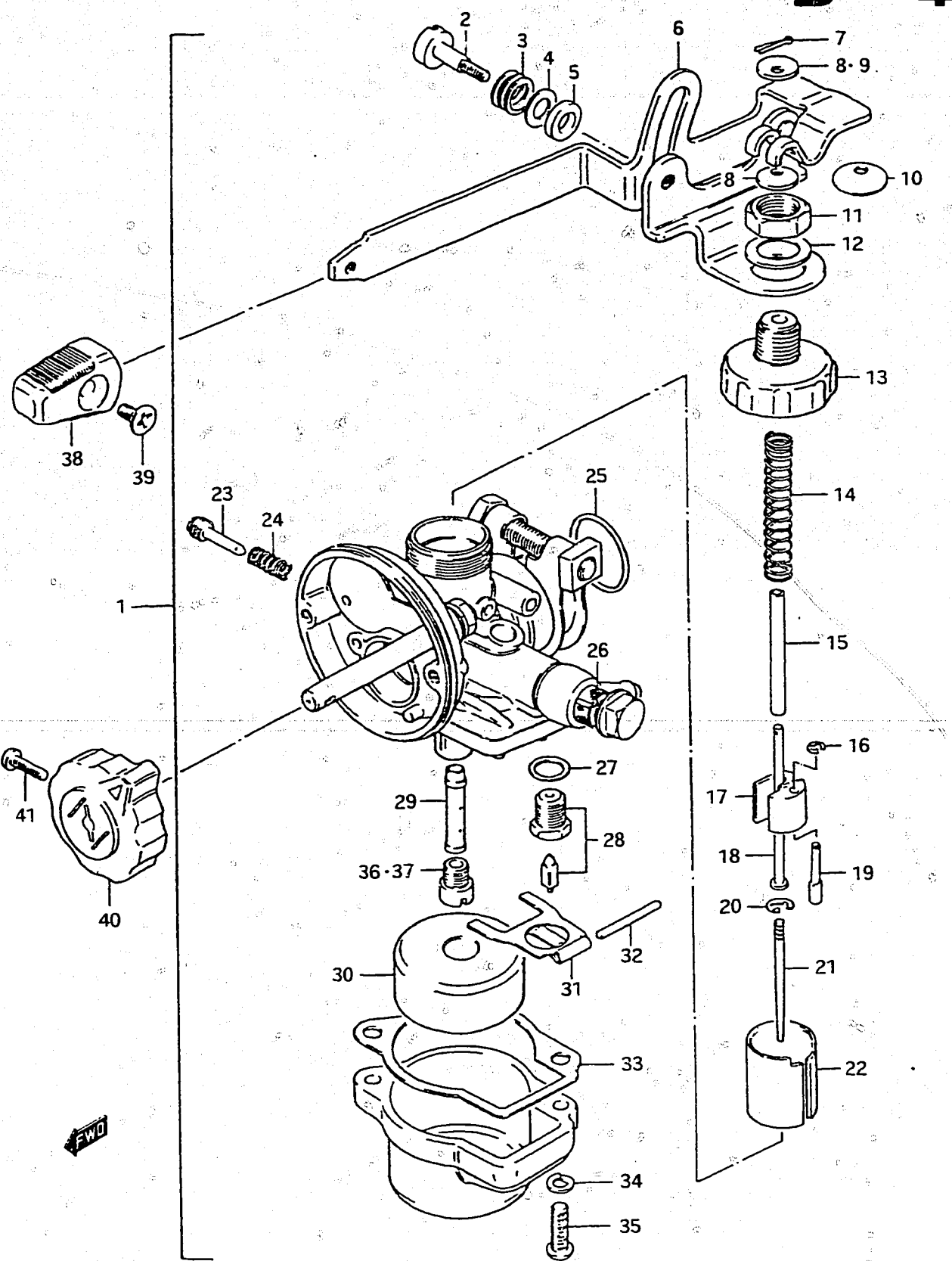

FIG.3

B-5

FIG.3 CARBURETOR

Ref. No.	Part No.	Description	Q'ty	Remarks
			ALL	
32	13254-98410	•PIN, float	1	
33	13251-98410	•GASKET	1	
34	08321-21048	•LOCK WASHER	2	
35	02112-04168	•SCREW	2	
36	09491-95004	•JET, main (95)	1	
37-1	09491-90006	JET, main (90)	1	} OPT
37-2	09491-85005	JET, main (85)	1	
37-3	09491-20013	JET, main (100)	1	
38	88851-64000	KNOB, throttle link	1	
39	02122-03068	SCREW	1	
40	13631-98400	KNOB, choke	1	
41	02112-03108	SCREW	1	

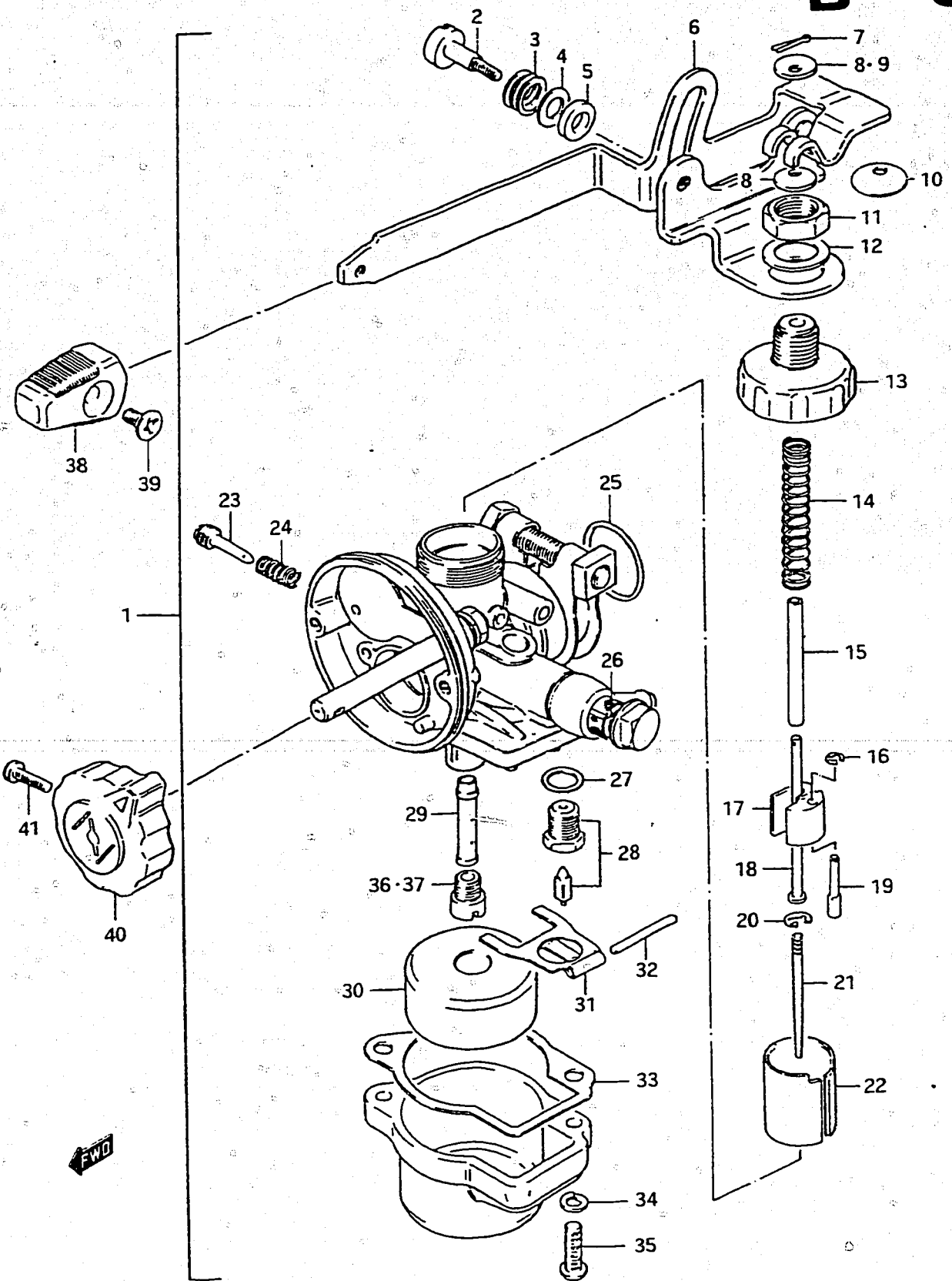
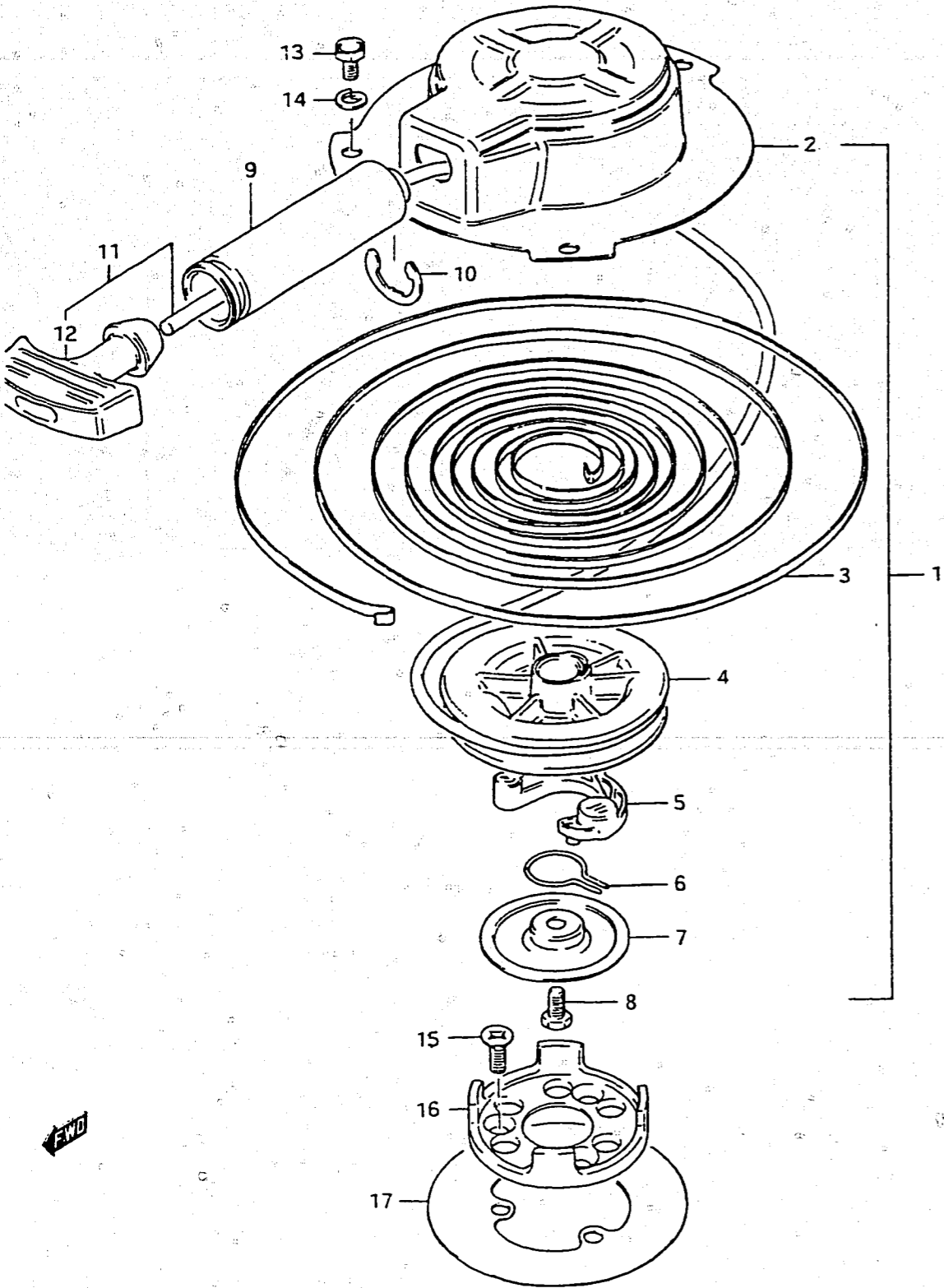

FIG.4

B - 6

FIG.4 STARTER



Ref. No.	Part No.	Description	Q'ty		Remarks
			ALL		
1	18100-98401	STARTER, recoil	1		
2	18111-98400	·CASE, starter	1		
3	18142-98400	·SPRING, recoil	1		
4	18121-98400	·DRUM, sheave	1		
5	18131-98400	·PAWL, drive	1		
6-1	18145-98400	·SPRING, pilot shaft	1		model G
6-2	18153-98410	·SPRING, pilot shaft	1		model J, VZ from 18145-98400
7	18151-98400	·PLATE	1		
8-1	18153-98400	·BOLT, pivot	1		
8-2	18332-98400	·BOLT, pivot	1		from 18153-98400
9	18181-98400	·GUIDE, rope	1		
10	18183-98400	·E RING	1		
11-1	18170-98401	·GRIP ASSY, starter	1		
11-2	18200-98401	·GRIP ASSY, starter	1		from 18170-98401
12	18210-98400	·GRIP	1		
13-1	01107-06108	BOLT	2		model G, J
13-2	01907-06108	BOLT	2		model VZ to 01107-06108
14	08321-21068	LOCK WASHER	2		
15	02122-06128	SCREW	3		
16	18411-98401	CUP, starter	1		
17	32725-98400	INSULATOR, magneto	1		

FIG.5

B - 7

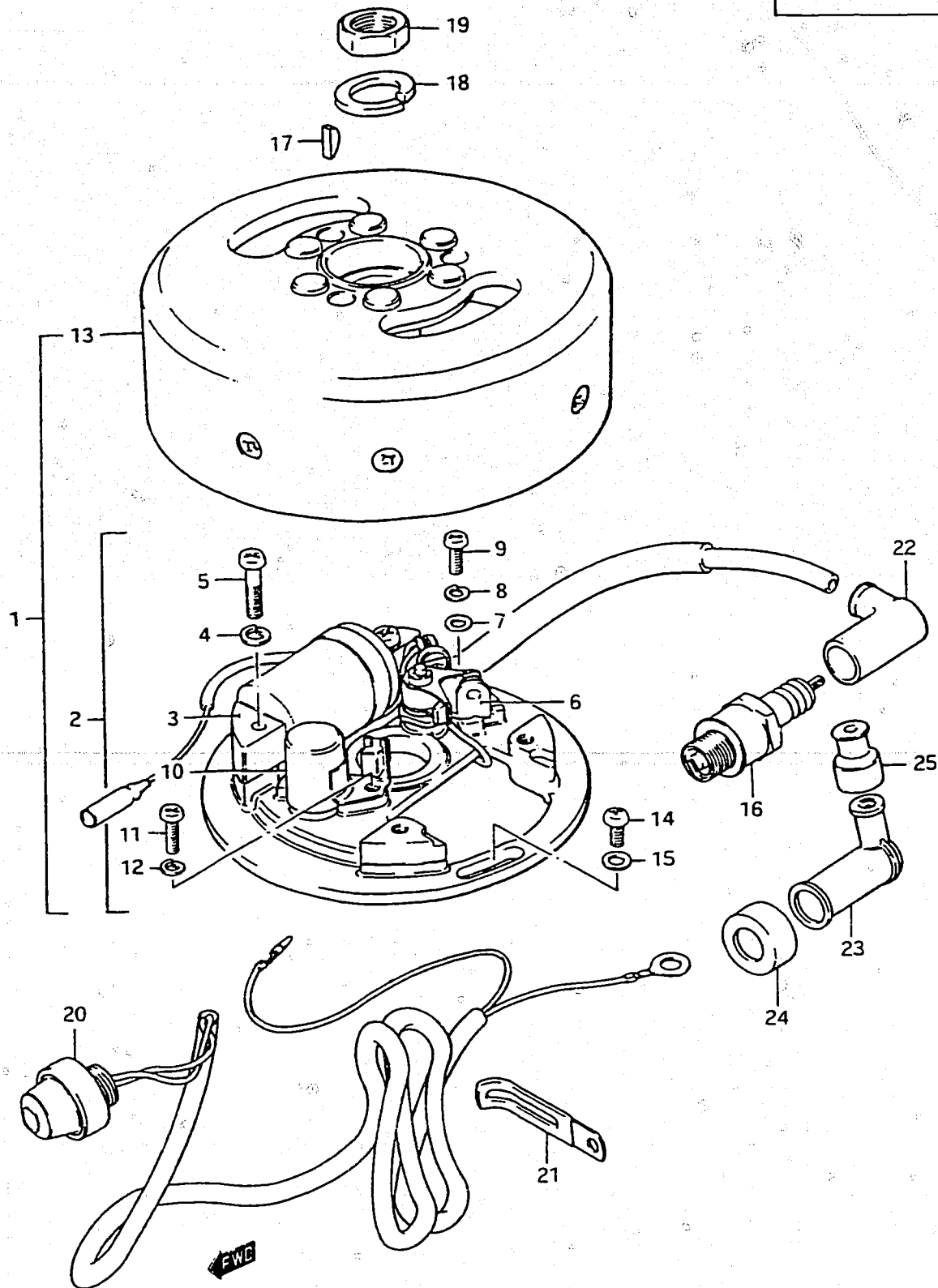

FIG.5 ELECTRICAL 1

Ref. No.	Part No.	Description	Q'ty	Remarks
		(model G,J)		
1	32100-98431	MAGNETO ASSY	1	
2-1	32101-98433	·STATOR ASSY	1	model G
2-2	32101-98434	·STATOR ASSY	1	from 32101-98433
3	32140-98431	··COIL, ignition	1	
4	08321-21058	··LOCK WASHER	2	
5	02112-05258	··SCREW	2	
6	32240-98034	··POINT ASSY, contact	1	
7	08322-21048	··WASHER	1	
8	08321-21048	··LOCK WASHER	1	
9	02311-04108	··SCREW	1	
10	32341-98430	··CONDENSER	1	
11	02112-04108	··SCREW	1	
12	08321-21048	··LOCK WASHER	1	
13	32102-98431	·ROTOR ASSY	1	
14	02112-05128	SCREW	2	
15	08322-21058	WASHER	2	
16-1	09482-00143	SPARK PLUG (BR5HS,NGK)	1	model G
16-2	09482-00142	SPARK PLUG (B4H,NGK)	1	model J,~0201-114150
16-3	09482-00143	SPARK PLUG (BR5HS,NGK)	1	model J,0201-114151~
17	08341-31039	KEY	1	
18	08321-31128	LOCK WASHER	1	
19	08310-22128	NUT	1	
20	37800-93350	SWITCH ASSY, engine stop	1	
21	09404-06413	CLAMP, stop switch lead cord	1	
22	33510-93510	CAP, spark plug	1	model G model J 0201-114151~
23	33510-22010	CAP, spark plug	1	model J,~0201-114150
24	33541-93310	SEAL, spark plug	1	
25	33542-98000	SEAL, high tension cord	1	

FIG.6 (B-9) : model VZ

FIG.6

B - 9

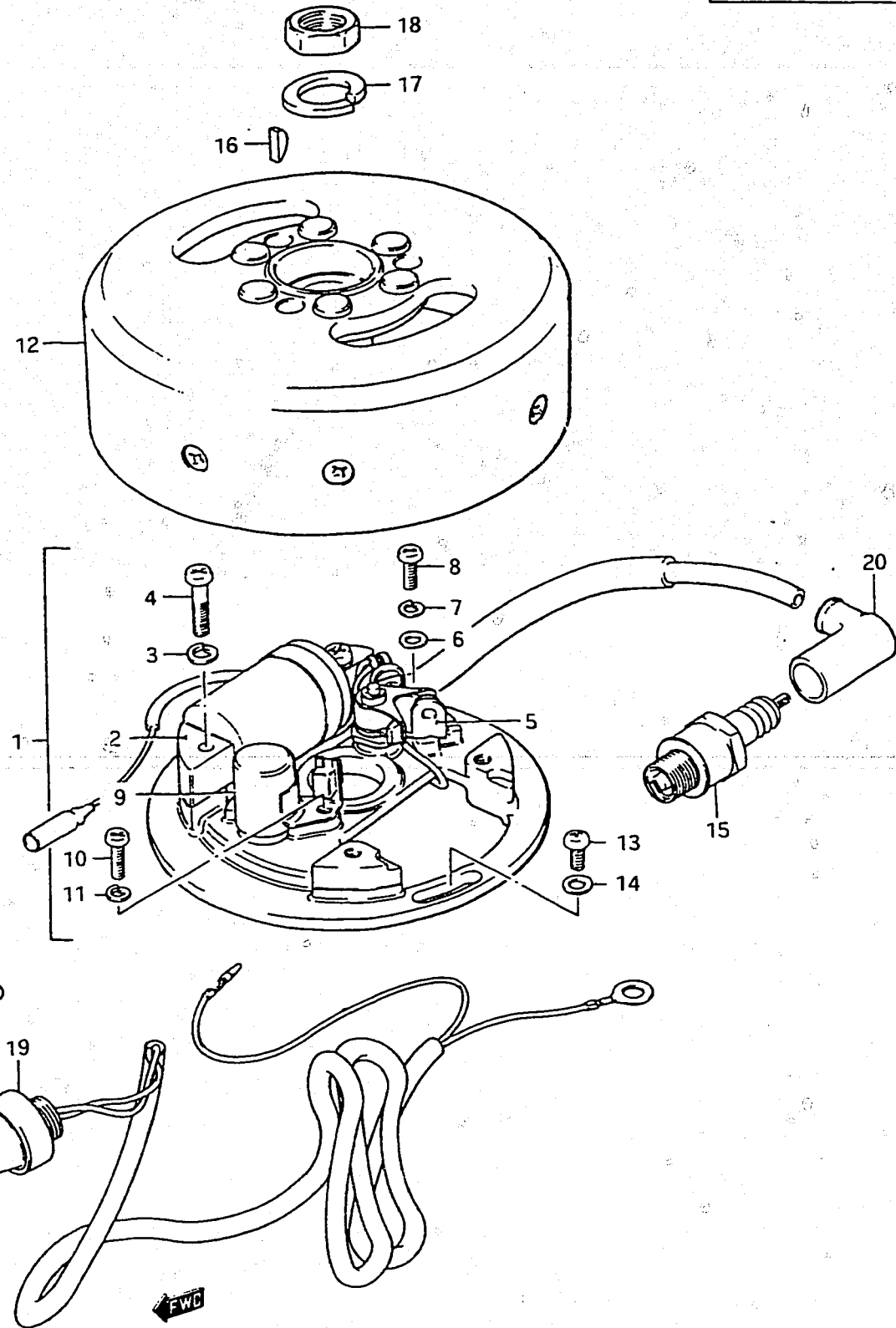

FIG.6 ELECTRICAL 2

Ref. No.	Part No.	Description	Q'ty	Remarks
		(model VZ)		
1	32101-98435	STATOR ASSY	1	
2	32140-98431	·COIL, ignition	1	
3	08321-21058	·LOCK WASHER	2	
4	02112-05258	·SCREW	2	
5	32240-98034	·POINT ASSY, contact	1	
6	08322-21048	·WASHER	1	
7	08321-21048	·LOCK WASHER	1	
8	02112-04108	·SCREW	1	
9	32341-98430	·CONDENSER	1	
10	02112-04108	·SCREW	1	
11	08321-21048	·LOCK WASHER	1	
12	32102-98431	ROTOR ASSY	1	
13	02112-05128	SCREW	2	
14	08322-21058	WASHER	2	
15-1	09482-00143	SPARK PLUG (BR5HS,NGK)	1	
15-2	09482-00142	SPARK PLUG (B4H,NGK)	1	E13
16	08341-31039	KEY	1	
17	08321-31128	LOCK WASHER	1	
18	08310-22128	NUT	1	
19	37800-93350	SWITCH ASSY, engine stop	1	
20	33510-95510	CAP, spark plug	1	
21	09404-06413	CLAMP, magneto lead wire	1	

FIG.5 (B-7) : model G, J

FIG. 8

B - 13

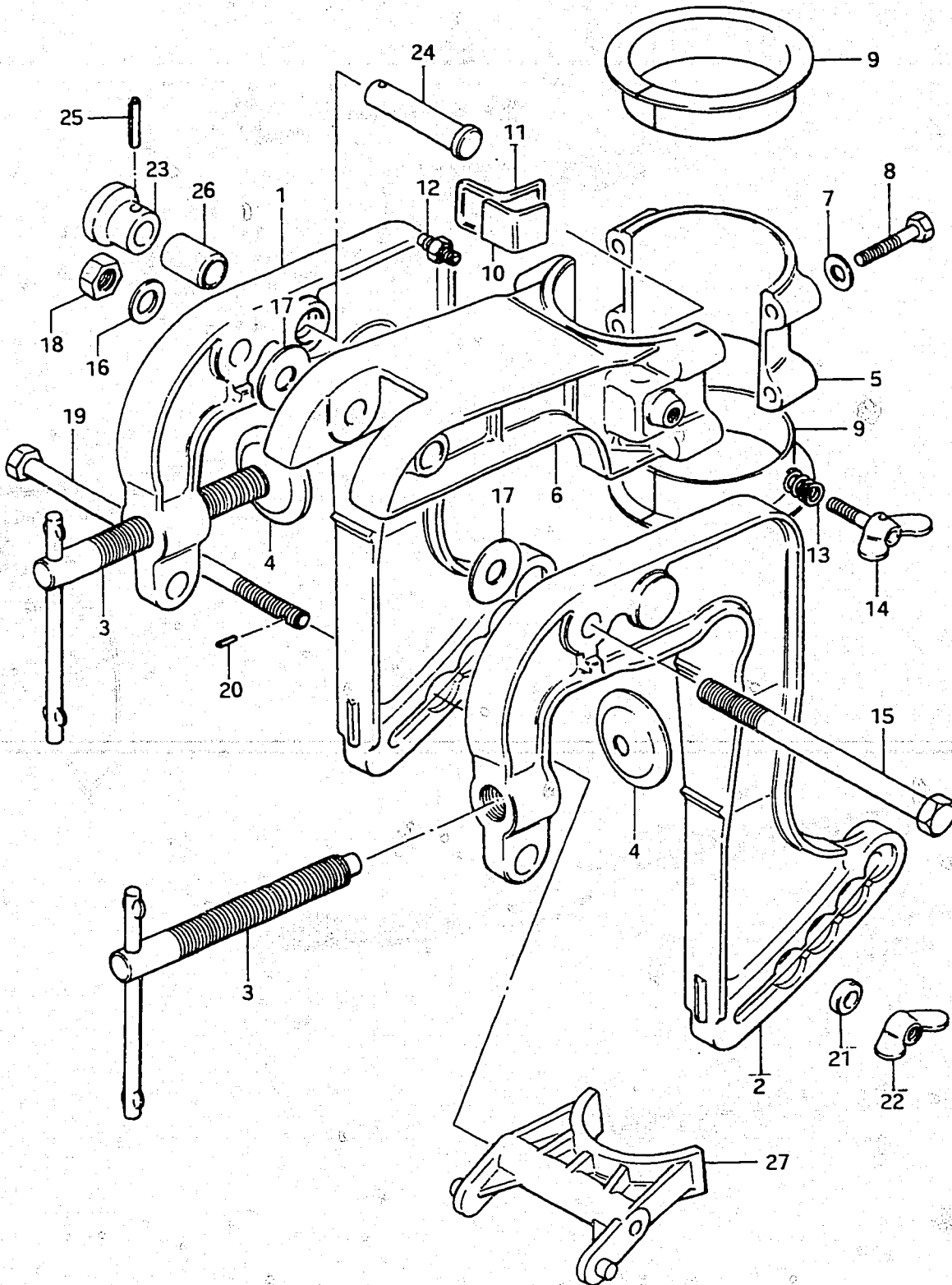
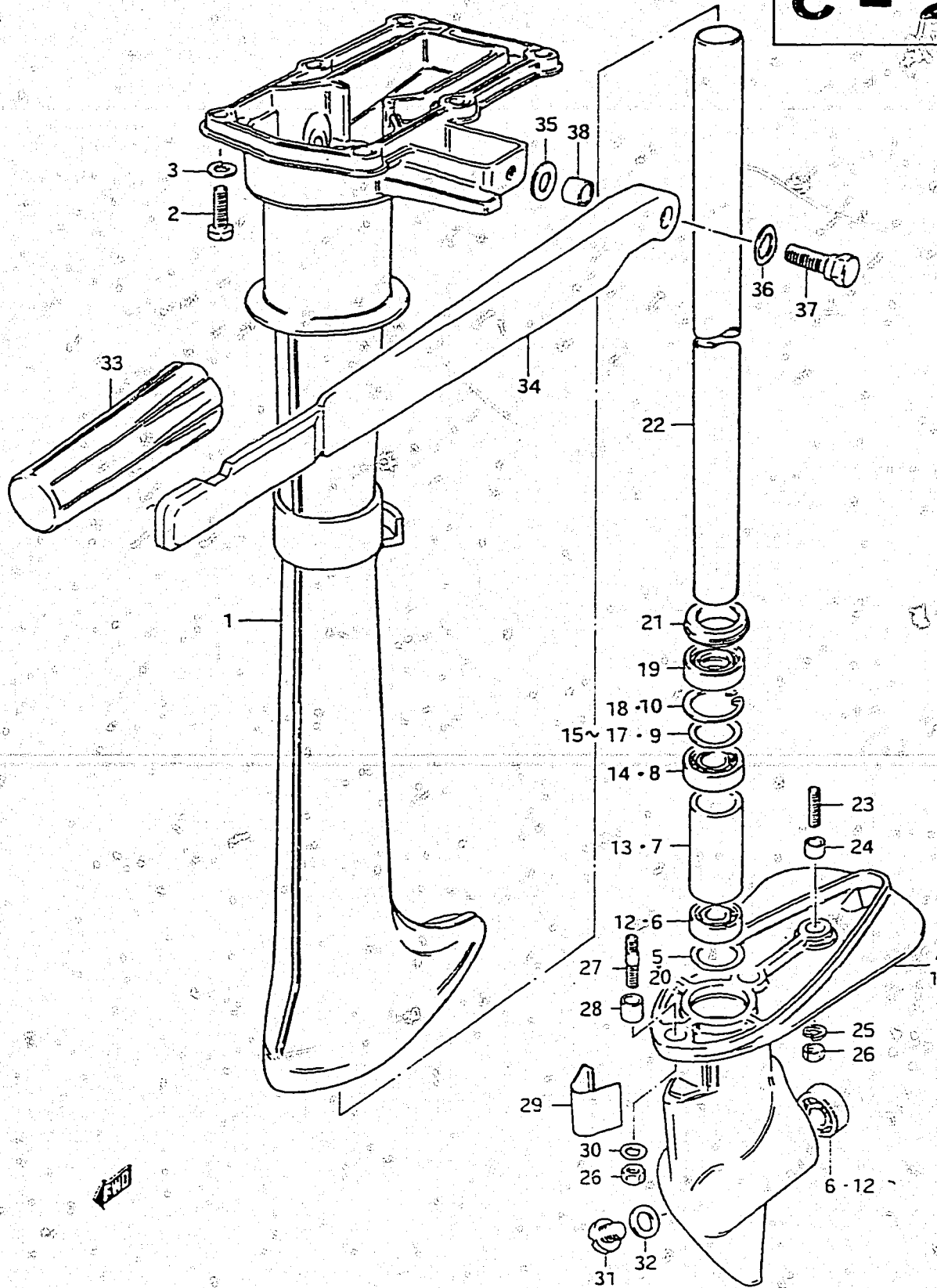

FIG.8 CLAMP BRACKET / SWIVEL BRACKET 2

Ref. No.	Part No.	Description	Q'ty	VZ	Remarks
(model VZ)					
1	41110-98401-01J	BRACKET, clamp RH	1		
2	41120-98400-01J	BRACKET, clamp LH	1		
3	41210-98401	SCREW, clamp	2		
4	41213-98100	PLATE, clamp	2		
5	43121-98404-01J	COVER, swivel bracket	1		
6	43111-98406-01J	BRACKET, swivel	1		
7	09160-06015	WASHER, swivel	4		6.5x13x1
8	09100-06022	BOLT, swivel	4		6x35
9	43711-98401	BUSHING, steering	2		
10	43415-98401	PLATE, steering adjuster	1		
11	43416-98401	RUBBER, steering adjuster	1		
12	22511-99000	GREASE NIPPLE	1		
13	09440-09012	SPRING, steering adjuster	1		L:15
14	09119-06038	BOLT, steering adjuster	1		
15	09100-08187	BOLT, swivel shaft	1		8x105
16	09160-08015	WASHER	1		8.5x16x1.2
17	09160-08014	WASHER, tilt friction	2		8.5x23x1.5
18	09159-08018	NUT, swivel shaft	1		
19	09101-06006	BOLT, tilt lock	1		6x115
20	09205-03010	PIN, tilt lock	1		3x6
21	09180-06096	SPACER, tilt lock	1		6.5x13.5x7.5
22	09144-06004	WING NUT, tilt lock	1		
23	41221-98400	KNOB, tilt stopper	1		
24	09200-10009	PIN	1		
25	09205-03012	PIN	1		
26	09300-10006	BUSHING	1		
27	45411-98402	BLOCK, thrust	1		

FIG.7 (B-11) : model G, J

FIG.9



C - 2

FIG.9 DRIVE SHAFT HOUSING / GEAR CASE / HANDLE

Ref. No.	Part No.	Description	Q'ty		Remarks
			ALL		
1	52111-98401-01J	HOUSING, drive shaft	1		
2	09100-06020	BOLT (6x20)	6		
3	09162-06001	LOCK WASHER	6		
4-1	55100-98810-01J	CASE SET, gear	1		from 55100-98810-01J to 55110-98401-01J
4-2	55100-98811-01J	CASE SET, gear	1		
5	09181-20004	·SHIM, bearing stopper	1		20x26x0.5
6	08113-60000	·BEARING	2		(model G)
7	09180-19004	·SPACER, drive shaft bearing	1		19x25.4x1.5
8	09262-12001	·BEARING, drive shaft	1		12x28x8
9-1	08221-22283	SHIM, bearing (T:0.1)	AR(0~2)		
9-2	08221-22284	SHIM, bearing (T:0.2)	AR(0~2)		
9-3	08221-22285	SHIM, bearing (T:0.5)	AR(0~1)		
10	08331-21289	CIRCLIP	1		
11-1	55110-98401-01J	CASE SET, gear (Ref.No.12~18)	1		to 55110-98402-01J
11-2	55110-98402-01J	CASE SET, gear (Ref.No.12~20)	1		
12	08113-60000	·BEARING	2		
13	09180-19004	·SPACER, drive shaft bearing	1		19x25.4x1.5
14	09262-12001	·BEARING, drive shaft	1		12x28x8
15	08221-22283	·SHIM, bearing (T:0.1)	AR(0~2)		
16	08221-22284	·SHIM, bearing (T:0.2)	AR(0~2)		(model J, VZ)
17	08221-22285	·SHIM, bearing (T:0.5)	AR(0~2)		
18	08331-21289	·CIRCLIP	1		
19	09289-12002	(·)OIL SEAL, drive shaft housing	1		12x28x8
20	09181-20004	(·)SHIM, bearing stopper	1		20x26x0.5
21	09305-20001	BUSHING, seal pipe	1		
22	57151-98400	PIPE, drive shaft seal	1		
23	09108-06022	STUD BOLT, gear case 2	1		6x12
24	09206-09007	PIN 2(9x5)	1		
25	09162-06001	LOCK WASHER	1		
26	09140-06004	NUT	2		
27	09108-06032	STUD BOLT, gear case 1	1		6x20
28	09206-09001	PIN 1(9x10)	1		

FIG. 9

C - 3

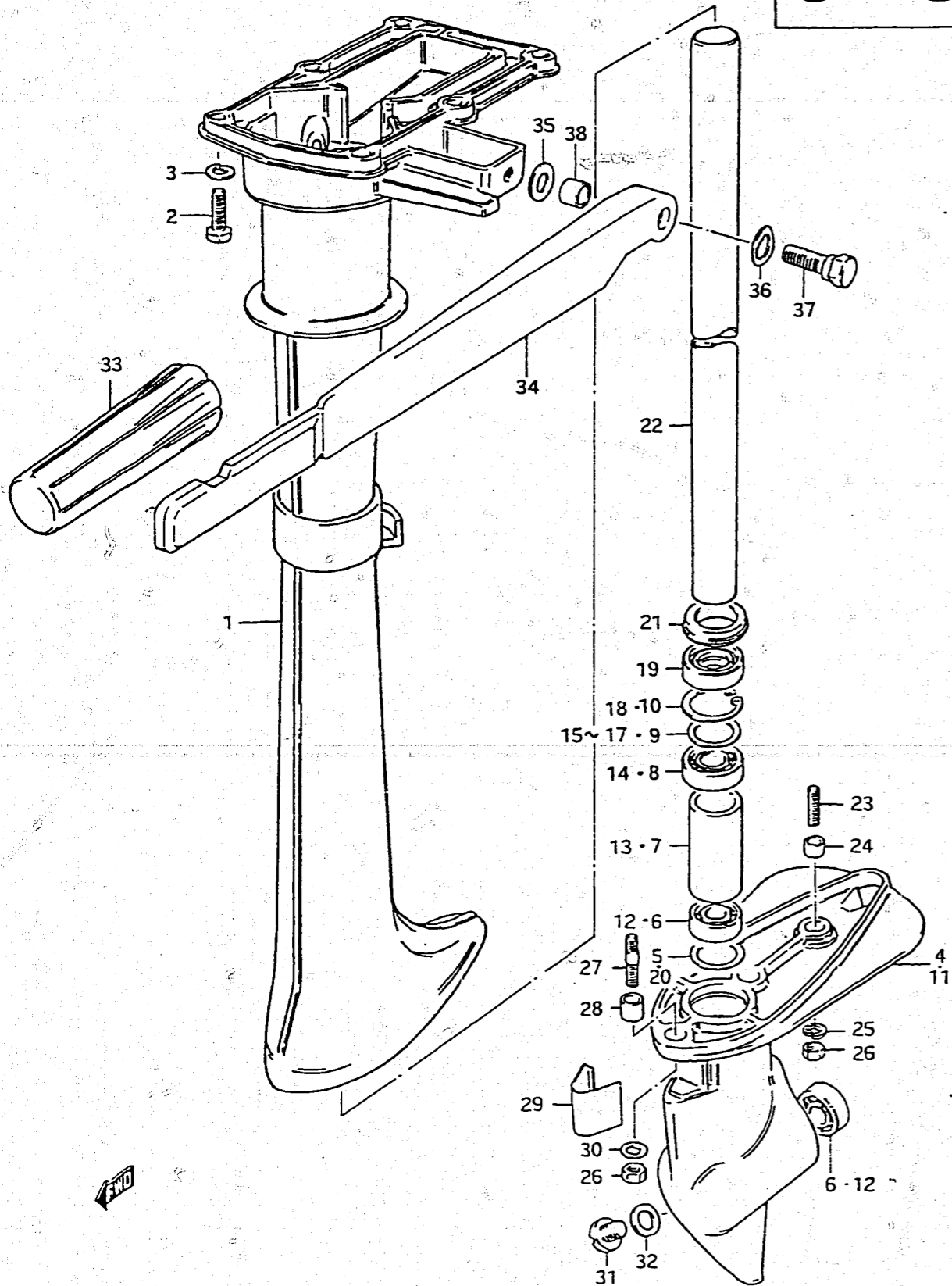

FIG. 9 DRIVE SHAFT HOUSING / GEAR CASE / HANDLE

Ref. No.	Part No.	Description	Q'ty	ALL	Remarks
29	53131-98400-01J	COVER, gear case bolt	1		
30	09160-06015	WASHER (6.5x16x2.3)	1		
31-1	09248-10003	PLUG, drain	1		model G
31-2	09248-10004	PLUG, drain (from 09248-10003)	1		model J, VZ
32-1	09168-10004	GASKET, drain plug (10x17x2) to 09168-10022	1		model G
32-2	09168-10022	GASKET, drain plug (10x17x2)	1		model J, VZ
33	63211-98400	GRIP, handle	1		
34-1	63111-98402-01J	HANDLE, tiller	1		model G, J
34-2	63111-98403-01J	HANDLE, tiller	1		model VZ
35-1	09160-08014	WASHER, handle pivot 2	1		d:8.5φ, ~0201-110032 model G, J
35-2	09160-08055	WASHER, handle pivot 2	1		d:8.2φ, 0201-110033~ model J, VZ
36-1	09164-10006	WASHER, handle pivot 1	1		model G, J
36-2	09164-10006	WASHER, handle pivot 1	2		model VZ
37-1	09111-08033	BOLT, handle pivot	1		model G, J
37-2	09111-08049	BOLT, handle pivot	1		model VZ
38	09306-10009	BUSHING, handle	1		model VZ

FIG. 10

C - 4

FIG. 10 WATER PUMP

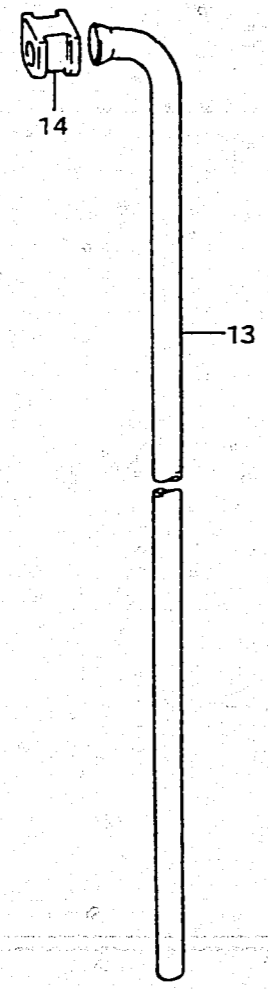

FWD

Ref. No.	Part No.	Description	Q'ty	ALL	Remarks
1	17410-98400-01J	CASE, water pump	1		
2	17411-98400-01J	CASE, water pump	1		to 17410-98400-01J model G
3	09289-10003	OIL SEAL, water pump case	1		10x26x8
4	08113-60000	BEARING, propeller shaft	1		
5	09280-48002	O RING, water pump case	1		ID:47.4,d:2.6
6	09108-06032	STUD BOLT (6x12)	2		
7	17471-98400-01J	COVER, pump case	1		
8	09160-06015	WASHER (6.5x13x1)	2		
9	09140-06004	NUT	2		
10	09202-02006	PIN, pump impeller (2.9x14)	1		
11-1	17461-98401	IMPELLER, water pump	1		model G
11-2	17461-98402	IMPELLER, water pump	1		model J, VZ from 17461-98401
12	09305-06007	BUSHING, water tube	1		
13	17561-98400	TUBE, water (L:515)	1		
14	09309-06005	GROMMET, water tube	1		

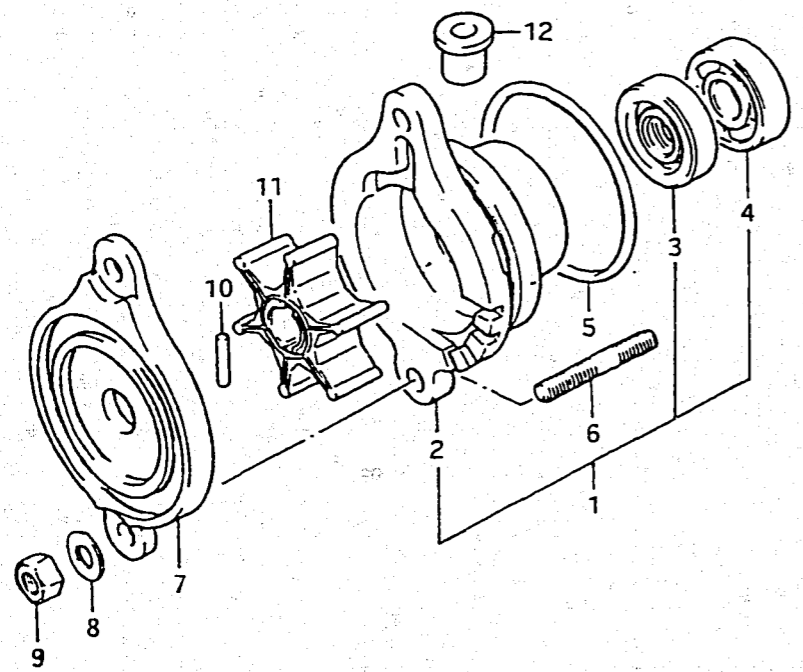
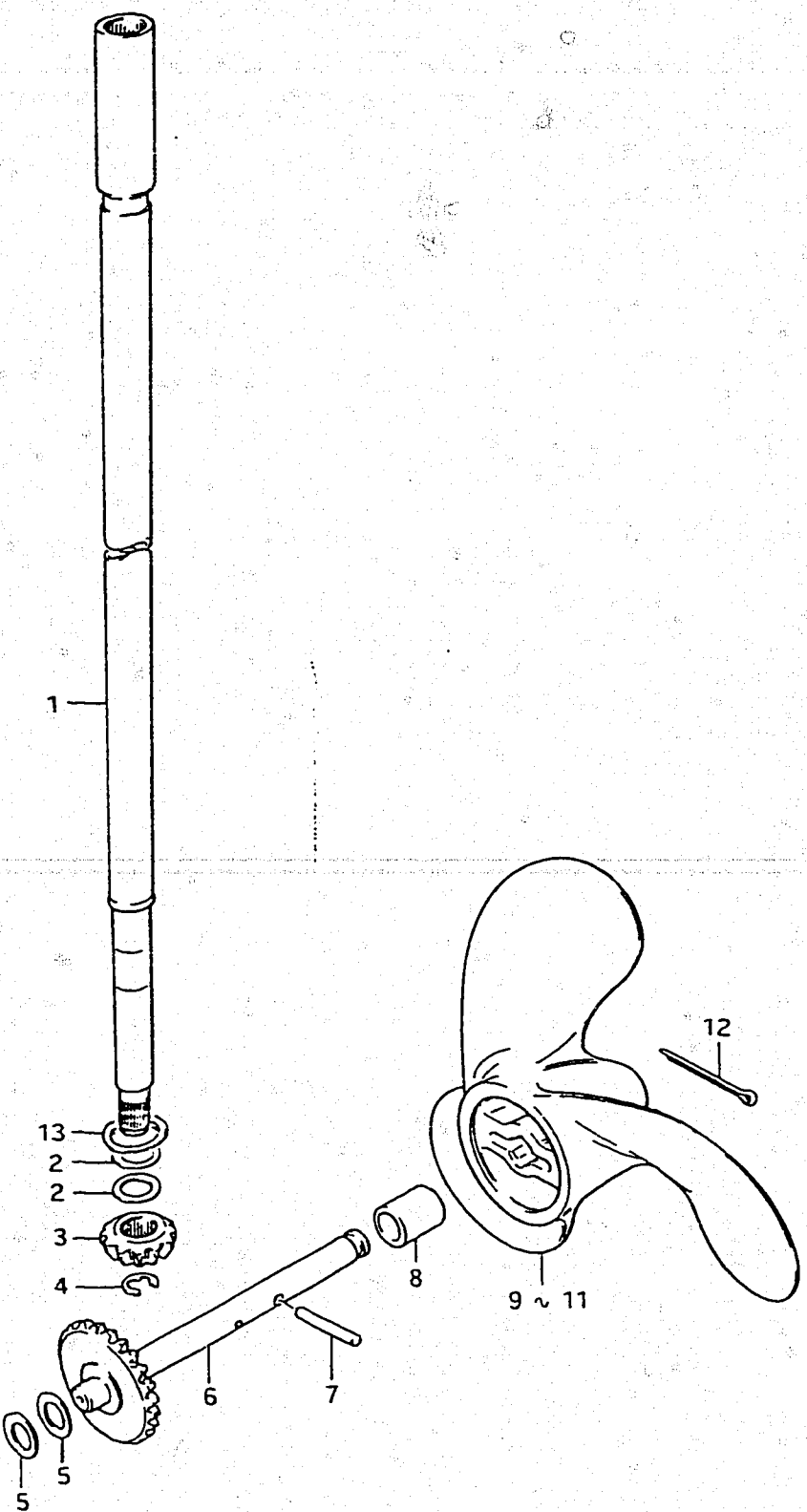

FIG. 11

C - 5

FIG.11 TRANSMISSION / PROPELLER



Ref. No.	Part No.	Description	Q'ty		Remarks
			ALL		
1	57110-98400	SHAFT, drive	1		
2-1	08221-10165	SHIM, pinion (T:0.5)	AR(0~2)		
2-2	08221-10164	SHIM, pinion (T:0.2)	AR(0~2)		
2-3	08221-10163	SHIM, pinion (T:0.1)	AR(0~2)		
3	57311-98400	PINION	1		
4	08332-11068	E RING	1		
5-1	08221-10165	SHIM, gear (T:0.5)	AR(0~2)		
5-2	08221-10164	SHIM, gear (T:0.2)	AR(0~2)		
5-3	08221-10163	SHIM, gear (T:0.1)	AR(0~2)		
6	57610-98401	SHAFT, propeller (NT:23)	1		
7	09202-04002	SHEAR PIN	1		
8	09180-10044	SPACER (10x14x17)	1		
9-1	58111-98401-01T	PROPELLER (A510)(3x188x135)	1		to 58111-98402-01T model G
9-2	58111-98402-01T	PROPELLER (A510)(3x188x135)	1		model J, VZ
10-1	58111-98451-01T	PROPELLER (A500)(3x188x122)	1		to 58111-98452-01T model G
10-2	58111-98452-01T	PROPELLER (A500)(3x188x122)	1		model J, VZ
11-1	58111-98462-01T	PROPELLER (A400)(3x188x115)	1		to 58111-98463-01T model G STD
11-2	58111-98463-01T	PROPELLER (A400)(3x188x115)	1		to 58111-98464-01T model G
11-3	58111-98464-01T	PROPELLER (A400)(3x188x115)	1		model J, VZ, 0201-112086~
12	09204-02001	COTTER PIN	1		
13	09181-20004	SHIM, bearing stopper	1		20x26x0.5, model J

FIG. 12

C - 6

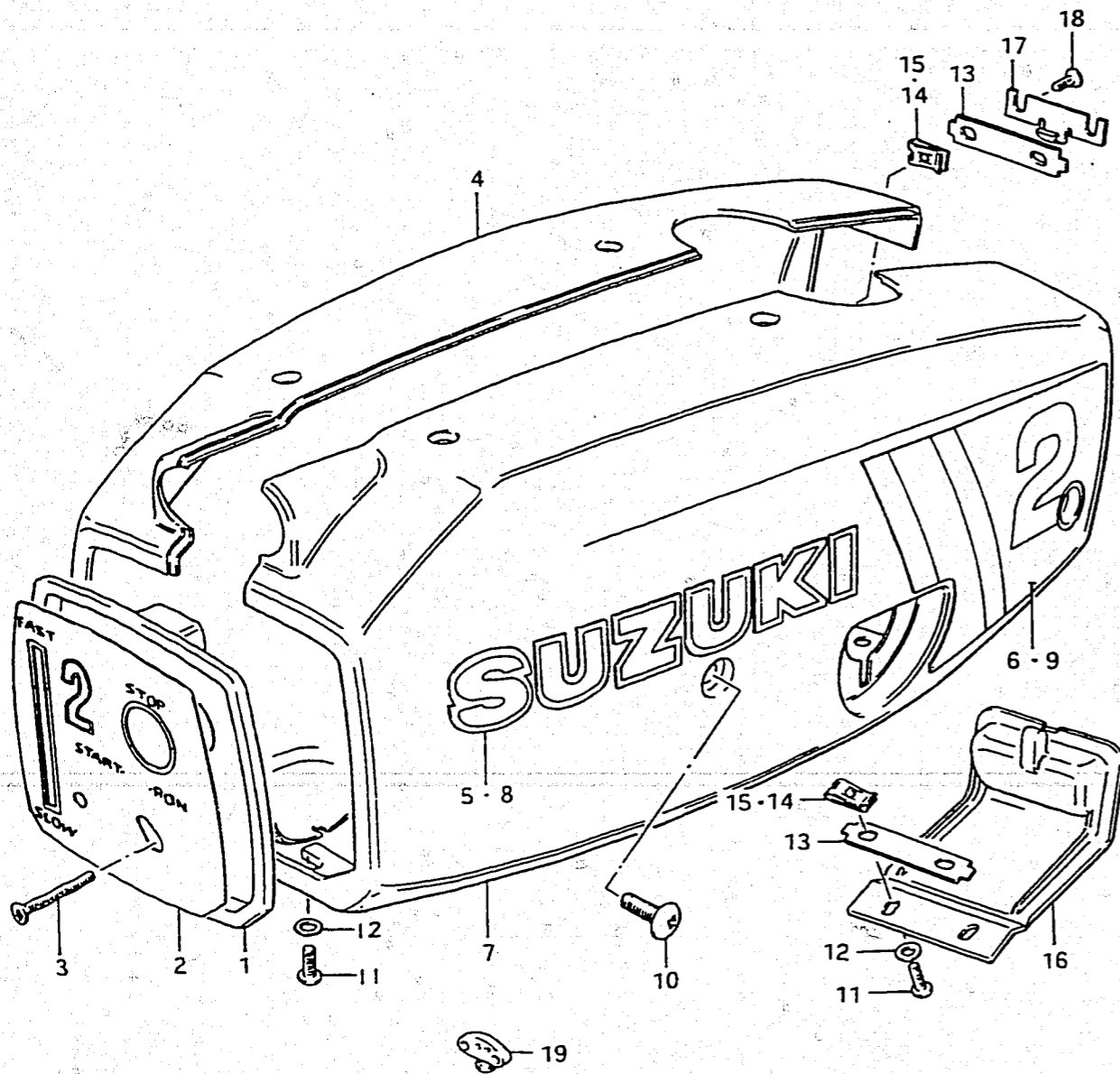

FIG. 12 ENGINE COVER

Ref. No.	Part No.	Description	Q'ty		Remarks
			ALL		
1	61420-98400	EMBLEM, engine cover front	1		
2	61422-98402	MARK, front emblem	1		
3	09126-04003	SCREW (4x35)	2		
4-1	61460-98840-01T	COVER SET, engine RH	1		model G
4-2	61460-98841-01T	COVER SET, engine RH	1		model J, VZ from 61460-98840-01T
5-1	61441-98401	·EMBLEM, "SUZUKI"	1		model G
5-2	61441-98410	·EMBLEM, "SUZUKI"	1		model J, VZ from 61441-98401
6	61445-98410	·STRIPE, side RH	1		
7-1	61470-98830-01T	COVER SET, engine LH	1		model G
7-2	61470-98831-01T	COVER SET, engine LH	1		model J, VZ from 61470-98830-01T
8-1	61441-98401	·EMBLEM, "SUZUKI"	1		model G
8-2	61441-98410	·EMBLEM, "SUZUKI"	1		model J, VZ from 61441-98401
9	61455-98410	·STRIPE, side LH	1		
10	09125-06025	SCREW (6x20)	4		
11-1	09125-05028	SCREW (5x12)	4		model G
11-2	09125-05028	SCREW (5x12)	1		model J
11-3	09125-05029	SCREW (5x16)	1		
11-4	09125-05035	SCREW (5x25) model VZ	1		
12-1	09160-05010	WASHER (5.5x10x0.8)	4		model G, J
12-2	09160-05010	WASHER (5.5x10x0.8)	3		model VZ
12-3	08322-21058	WASHER	1		model VZ
13-1	61465-98402	PLATE, engine cover	4		model G
13-2	61490-98400	PLATE, engine cover	4		from 61465-98402
14	09148-05011	NUT	8		model G
15	09148-05011	NUT	4		
16	61481-98401	HINGE, engine cover	1		
17	61485-98401	SPRING, engine cover hinge	1		
18	09126-05003	SCREW (5x12)	6		
19	61521-98400	HOLDER, shear pin	1		

FIG. 13

C - 8

FIG. 13 FUEL TANK

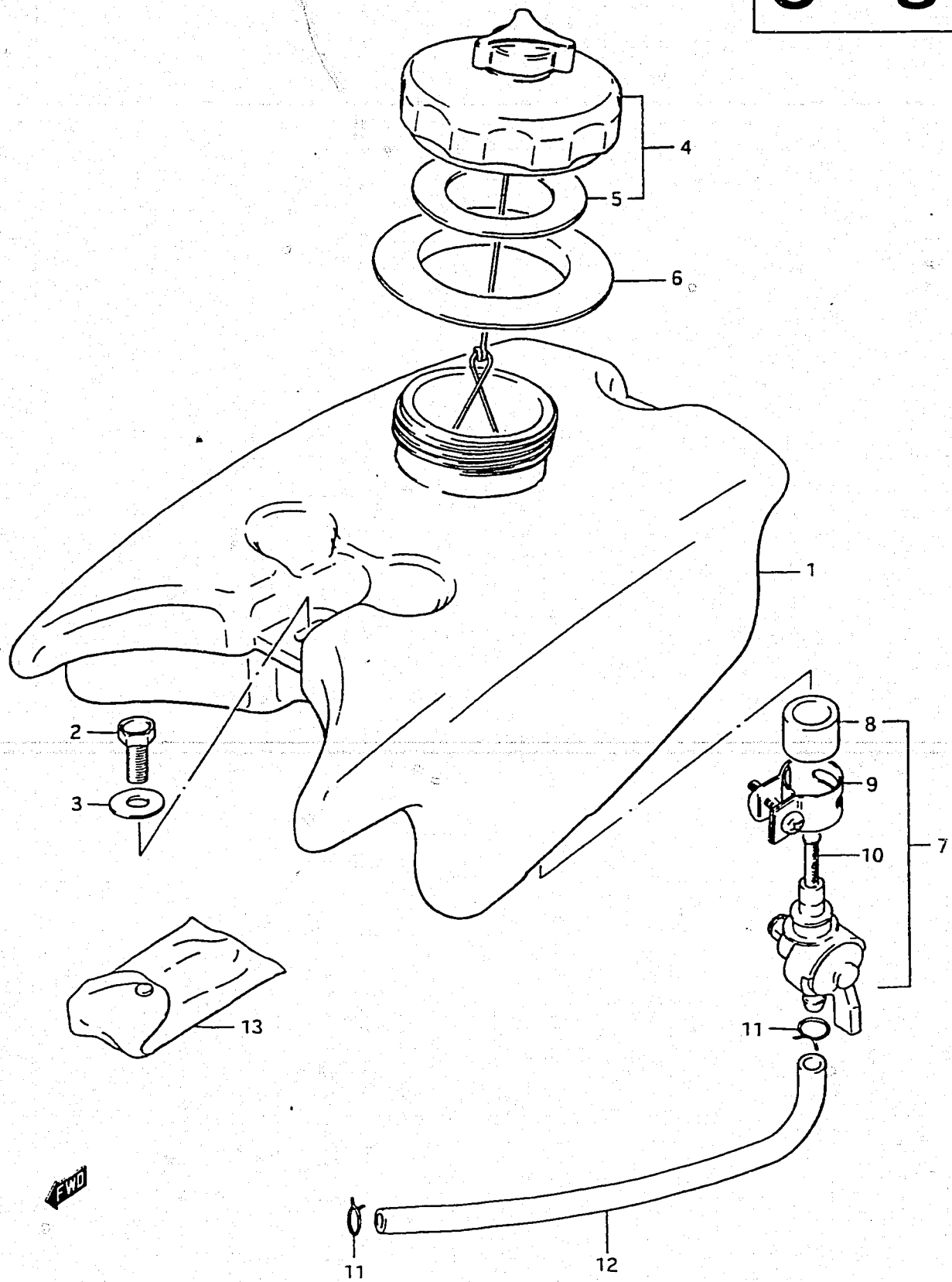

Ref. No.	Part No.	Description	Q'ty	ALL	Remarks
1-1	65111-98402	TANK, fuel (threads L:11)	1		to 65111-98403, model G, J ~0201-111983
1-2	65111-98403	TANK, fuel (threads L:17)	1		model J, VZ, 0201-111984~
2-1	01107-06168	BOLT	2		model G, J
2-2	01907-06168	BOLT	2		model VZ to 01107-06168
3-1	09160-06051	WASHER (6x16x1.2)	2		to 09160-06052, model G
3-2	09160-06052	WASHER (6.5x16x1.2)	2		
4-1	65510-98402	CAP ASSY, fuel tank	1		threads L:7.5, model G, J ~0201-111983
4-2	65510-98403	CAP ASSY, fuel tank	1		model J, VZ, 0201-111984~ threads L:12.5
5	09168-32001	·GASKET (32x48x2.5)	1		
6	65281-98400	GROMMET, fuel tank	1		
7-1	66100-98400	COCK ASSY, fuel	1		to 66100-98401, model G
7-2	66100-98401	COCK ASSY, fuel	1		model J, VZ
8-1	66142-98400	·PIPE, joint	1		model G
8-2	66142-98401	·PIPE, joint	1		from 66142-98400 model J, VZ
9-1	66165-98400	·CLAMP	1		to 66165-98401, model G
9-2	66165-98401	·CLAMP	1		model J, VZ
10	66152-98400	·FILTER	1		
11	09401-09402	CLIP, fuel hose	2		
12	09343-05137	HOSE, fuel (L:500→215)	1		
13-1	09800-00178	TOOL SET (model G)	1		to 09800-00805
13-2	09800-00805	TOOL SET (model J)	1		to 09800-81800
13-3	09800-81800	TOOL SET (model VZ)	1		

DT2

FIG. 14

FIG.14 OPTIONAL

C - 9

Ref. No.	Part No.	Description	Q'ty	Remarks
			ALL	
1	99000-31120	SUZUKI SILICONE SEAL	1	for gear case, 50g
2	99000-31050	GASKET, liquid	1	for gear case, 100g
3	99000-25160	GREASE, water resistant	1	250g
4	99000-25170	GREASE, water resistant	1	50g
5	99000-22540	GEAR OIL, outboard moter	1	400cc
6	99000-25010	SUZUKI SUPER GREASE A	1	450g, for crank oil seal
7	99000-32050	THREAD LOCK "1342"	1	50g
8	99000-32020	THREAD LOCK SUPER "1333B"	1	50g
9-1	99000-21145	CCI OIL (1ℓx24, SHELL)	1	
9-2	99000-21460	CCI OIL (1ℓx24, MITSUBISHI)	1	
9-3	99000-21021	CCI OIL (4ℓx6)	1	
9-4	99000-21150	CCI OIL (200ℓ)	1	
9-5	99000-21250	CCI SUPER OIL (1ℓx24)	1	
10	09914-39911	HANGER, engine	1	
11	99000-32040	CEMENT, thread lock (200g)	1	
12-1	99000-10109-01T	PAINT (Francois White-2)	1	NET:90g
12-2	99000-10209-01J	PAINT (Andes Blue Metallic)	1	NET:90g
13-1	99000-10105-01T	PAINT (Francois White-2)	1	NET:500g
13-2	99000-10205-01J	PAINT (Andes Blue Metallic)	1	NET:500g

